

This drawing is the sole property of Miether Bearing Products and contains confidential and proprietary information. It is being provided to you for your use and may not be disclosed to any third party or used for any other purpose without Miether's prior written consent. The [materials] must be returned to the Company upon its demand. Your acceptance of these materials constitutes your acceptance of the foregoing terms.

C-32689

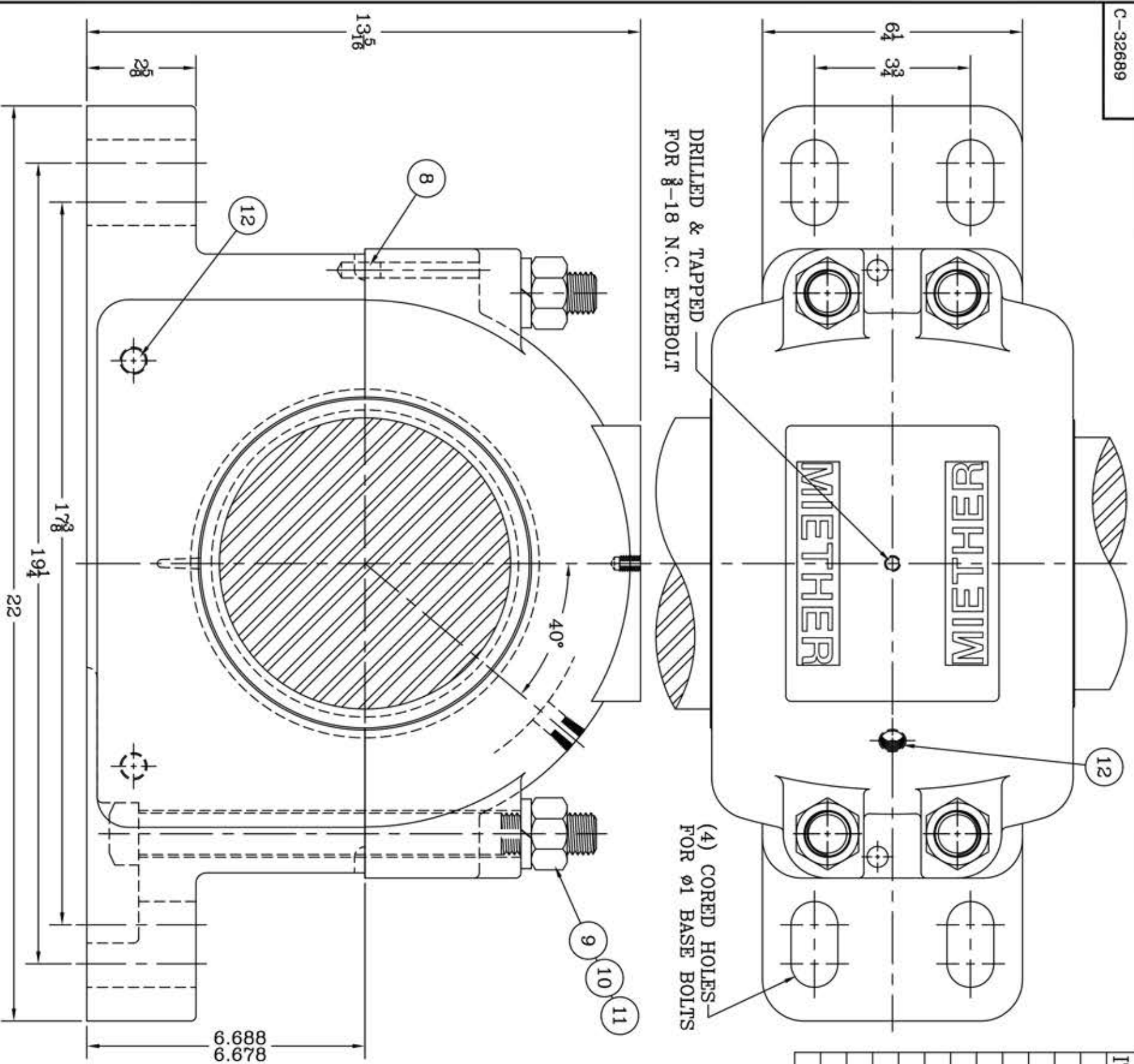

ITEM	DESCRIPTION	DETAIL	REQUIRED
1	HOUSING SAW 232	C-19595	1 1
2	SPHERICAL ROLLER BEARING	23232/W-33	1 1
3	STABILIZING RING SR-32-0	A-10608	1 0
4	LOCKNUT AN-32	B-10420	1 1
5	LOCKWASHER W-32	0025	1 1
6	TRIPLE SEAL RING LER-142 A	A-10640	1 1
7	TRIPLE SEAL RING LER-156 A	A-10588	1 1
8	DOWEL	Ø 1/2 x 3/4 LONG	2 2
9	CAP BOLT SQUARE HEAD	1"-8 NC x 11" LONG	4 4
10	CAP BOLT HEX. NUT	1"-8 NC	4 4
11	LOCKWASHER	1" SPLIT MED.	4 4
12	PIPE PLUG	3/8-18 NPT	3 3

REVISIONS	
SYMBOL	VALUE
✓	16
✓	32
✓	63
✓	125
✓	250
✓	500
✓	1000

TOLERANCE: UNLESS OTHERWISE SPECIFIED	
FRACTIONS	± 1/32"
DECIMALS	± .005"
CASTING	± 1/16"
ANGLES	± 0° 30'
WELD	± 1/16"

A.I.S.I. STANDARD FINISHES	
SYMBOL	VALUE
✓	16
✓	32
✓	63
✓	125
✓	250
✓	500
✓	1000

SAW 23232 07-00 x 06-01	
SCALE	HALF
DRAWN	AR
DATE	6/13/06
CHK:	

AN ALCO INDUSTRIES COMPANY  
BEARING PRODUCTS  
ODESSA, TX. USA

ASSEMBLY DRAWING	
SCALE	HALF
DRAWN	AR
DATE	6/13/06
CHK:	